

MERITOR®

Technical Bulletin

Verify That Snap Rings are Installed and Seated Correctly in the Weld Yoke and Slip Yoke Ear Grooves on Meritor's RPL 20 Series Permalube™ Inter-Axle Drivelines

Hazard Alert Messages

Read and observe all Warning and Caution hazard alert messages in this publication. They provide information that can help prevent serious personal injury, damage to components, or both.

⚠ WARNING

To prevent serious eye injury, always wear safe eye protection when you perform vehicle maintenance or service.

Park the vehicle on a level surface. Block the wheels to prevent the vehicle from moving. Support the vehicle with safety stands. Do not work under a vehicle supported only by jacks. Jacks can slip and fall over. Serious personal injury and damage to components can result.

Only inspect and service a driveline when the engine is OFF. A rotating driveline can cause serious personal injury.

How to Obtain Additional Maintenance and Service Information

Refer to Maintenance Manual MM-96147, Drivelines. To obtain this publication, visit Literature on Demand at meritorhvs.com or call ArvinMeritor's Customer Service Center at 800-535-5560.

How to Order the Gage Tool (Part Number PNR26-24-1)

Call ArvinMeritor's Customer Service Center at 800-535-5560 or order online at arvinmeritororders@archway.com. Specify part number PNR26-24-1.

Verify That Snap Rings are Installed and Seated Correctly in the Weld Yoke and Slip Yoke Ear Grooves

⚠ WARNING

Verify that snap rings are installed and seated correctly in the weld yoke and slip yoke ear grooves on Meritor's RPL 20 Series Permalube™ inter-axle drivelines. The snap rings retain the universal joint bearings. If one or both of the snap rings are missing from the weld yoke or slip yoke, or if the snap rings are not seated correctly, the driveline can separate from the vehicle during operation. Serious personal injury and damage to components can result.

1. Wear safe eye protection. Park the vehicle on a level surface. Block the wheels to prevent the vehicle from moving. Support the vehicle with safety stands.
2. Support one dual wheel with a jack to enable you to rotate the driveline.
3. Inspect the inter-axle driveline (Figure 1) to verify that snap rings are installed in the slip yoke and weld yoke ear grooves. The snap rings retain the weld yoke and slip yoke universal joint bearings. Figure 2.
 - **If one or both snap rings are missing from the weld yoke or slip yoke:** Replace the inter-axle driveline. Refer to Maintenance Manual MM-96147 for complete installation procedures.
 - **If snap rings are installed in the weld yoke and slip yoke ear grooves:** **Note:** If there is paint on the snap rings, use a pen knife or screwdriver to remove the paint before you use the gage tool. Insert the gage tool (part number PNR26-24-1) to verify that the snap rings are seated correctly. Figure 3. If the gage fits between the snap ring teeth and contacts the top surface of the universal joint bearing, the snap ring is seated correctly.

- **If you cannot insert the gage tool:** The snap rings are not seated correctly if the gage tool does not fit between the teeth of the snap ring and fully contact the top surface of the universal joint bearing. Replace the inter-axle driveline. Install new universal joint cap screws. Use a torque wrench to tighten them to 115-135 lb-ft (156-183 N•m). Refer to Maintenance Manual MM-96147 for complete installation procedures. 

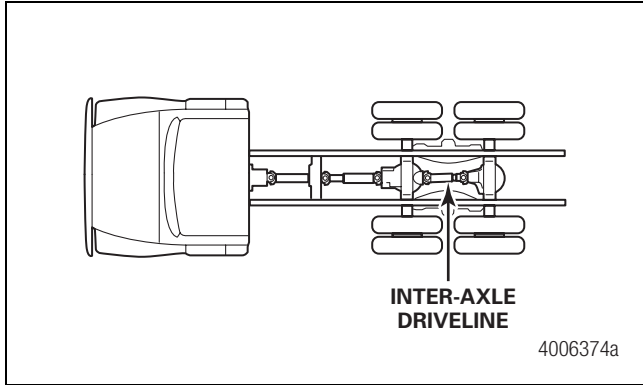

Figure 1

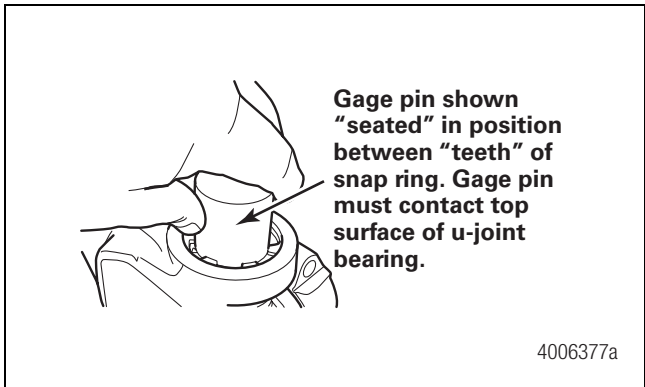

Figure 3

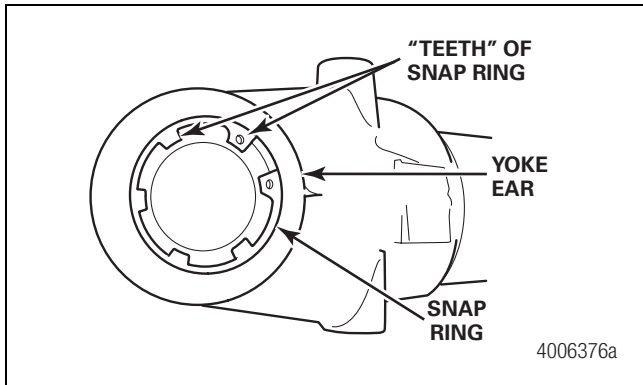

Figure 2

ArvinMeritor™

Meritor Heavy Vehicle Systems, LLC
 2135 West Maple Road
 Troy, MI 48084 USA
 800-535-5560
 arvinmeritor.com

Information contained in this publication was in effect at the time the publication was approved for printing and is subject to change without notice or liability. Meritor Heavy Vehicle Systems, LLC, reserves the right to revise the information presented or to discontinue the production of parts described at any time.

Copyright 2006
 ArvinMeritor, Inc.
 All Rights Reserved

Printed in USA

TP-06128
 Issued 09-06
 (16579/22882)